

CertainTeed

CERTA-LOK™ DROP PIPE

PVC Well Products



CertainTeed 

Quality made certain. Satisfaction guaranteed.

LOCK INTO THE ADVANTAGES OF CERTA-LOK™ PVC DROP PIPE

Certa-Lok™ Non-Threaded, Corrosion-Resistant PVC Drop Pipe

Certa-Lok™ PVC (Polyvinyl Chloride) Drop Pipe offers an instant, ready-to-use joint utilizing CertainTeed's unique, field-proven coupling/spline locking design, which allows submersible pumps to be set or pulled quickly and with confidence.

Certa-Lok PVC Drop Pipe is designed and manufactured to meet or exceed ASTM Specification D1785 requirements (SCH 80). Available in sizes 2" – 8", Certa-Lok PVC Drop Pipe is perfect for a wide range of deep and shallow-well applications, including:

- Domestic wells
- Irrigation wells
- Municipal wells
- Recharge wells
- Test pumps
- Offshore oil platform water supply systems



Certa-Lok PVC Drop Pipe offers you distinct advantages that will boost your bottom line.

Cost effective – Certa-Lok PVC Drop Pipe combines a competitive initial cost with a long life, making it the preferred product for submersible pump installations requiring 2" – 8" drop pipe.

Reliable – The Certa-Lok joint has been successfully used for over 30 years in various water supply applications.

Thread-free – With its groove and spline design, the Certa-Lok joint eliminates the need to constantly rotate the drop pipe for assembly and disassembly.

Easy to handle – 6" Certa-Lok PVC Drop Pipe weighs approx. 112 lbs. per 20' length compared to approx. 400 lbs. for 6" SCH 40 steel.

Easy to set and pull – The Certa-Lok joint is fast and easy to assemble and disassemble by hand. Just insert the pipe into the gasketed coupling, insert the locking spline and tighten the torque control screws. To disassemble, reverse these steps. For complete assembly instructions, see next page and back cover.

Weather resistant – Heat, cold, moisture, humidity and wind do not affect Certa-Lok PVC Drop Pipe joint assembly or disassembly.

Adaptable – Certa-Lok PVC Drop Pipe easily adapts to solvent weld discharge fittings such as Tees, Ells, Flanges, etc. Certa-Lok threaded adapters (PVC or stainless steel) allow easy connection to pumps, check valves and threaded discharge fittings.

Clean – Say goodbye to grease, thread lubricant and pipe dope that can contaminate water supplies.

Lower friction loss – Certa-Lok PVC Drop Pipe provides a flow coefficient of 150, vs. 100 for non-corroded metal drop pipe.

Chemical resistant – Certa-Lok PVC Drop Pipe can handle most corrosive fluids, subject to temperature service factors.

NSF listed, customer preferred – PVC compounds used in the manufacturing of Certa-Lok Drop Pipe are NSF61 listed after being tested for taste, color and toxicity. Many customers prefer to drink potable water pumped through PVC rather than water pumped through metal pipe.

Won't rust or corrode – The inherent properties of PVC prevent it from rusting and corroding like metal drop pipe.

Faster test pumping – Test pump installers can save considerable time and money by using quick, easy-to-assemble and disassemble Certa-Lok joints.

Readily available – Certa-Lok PVC Drop Pipe is available worldwide through your local CertainTeed Certa-Lok distributor.

RAPID JOINT ASSEMBLY

Certa-Lok PVC Drop Pipe is fast and easy to set and pull. You can assemble or disassemble the Certa-Lok joint in seconds – by hand, without any special tools. Since there are no threads, time spent rotating threaded pipe is completely eliminated. Follow these simple steps for rapid joint assembly:

1. Clean

Clean the joining surfaces and make sure gaskets are clean and evenly seated in the gasket grooves.

2. Lubricate

If lubrication is needed to ease joint assembly, soapy water or CertainTeed-approved PVC pipe lubricant can be applied to the joining surfaces prior to assembly. Apply only to the exposed gasket surface and to the tapered end of the drop pipe.

CAUTION: To maintain joint integrity, do not apply lubricant to the spline or to the spline grooves.

3. Assemble

Insert the drop pipe into the coupling until it seats against the coupling stop. This automatically aligns the locking grooves for receiving the spline. The spline is then inserted through the entry hole until it is fully seated. This securely locks the joint, while the gasket is designed to provide a reliable, watertight seal. The spline may then be cut so that only a short length protrudes from the coupling to facilitate future disassembly. In circumstances where there is a need to prevent sand infiltration into the joint (which can make coupling disassembly more difficult), wrap the coupling edges with waterproof tape and seal the spline entry holes with putty or similar material.

4. Tighten torque control screws

Using an allen wrench, tighten the torque control screws into the coupling until each just touches the pipe. Then tighten each screw one-half to one full turn or until snug.

CAUTION: Do not over-tighten. Over-tightening may result in leakage and/or coupling failure.



ENGINEERING SPECIFICATION

1.0 SCOPE

This specification covers Polyvinyl Chloride (PVC) Drop Pipe for submersible pumps, which utilizes a spline-lock mechanical joining system. Pipe is produced in nominal sizes 2" – 8".

2.0 REFERENCE DOCUMENTS

ASTM International:

ASTM D1784 – Standard Specification for Rigid PVC Compounds and Chlorinated PVC Compounds.

ASTM D1785 – Standard Specification for Poly (Vinyl Chloride) (PVC) Plastic Pipe, Schedules 40, 80, and 120.

ASTM D2837 – Standard Test Method for Obtaining Hydrostatic Design Basis for Thermoplastic Pipe Materials.

NSF International:

NSF14 – Plastic Piping System Components and Related Materials

NSF61 – Drinking Water System Components – Health Effects

3.0 REQUIREMENTS

3.1 Materials: Pipe and couplings shall be made from unplasticized PVC compounds having a minimum cell classification of 12454, as defined in ASTM D1784. The compound shall qualify for a Hydrostatic Design Basis (HDB) of 4000 psi for water at 73.4° F,

in accordance with the requirements of ASTM D2837. White pipe shall be supplied, unless otherwise agreed upon at time of purchase.

3.2 Approvals: Products intended for contact with potable water shall be evaluated, tested, and certified for conformance with NSF61, or the health effects portion of NSF14, by an acceptable certifying organization, when required by the regulatory authority having jurisdiction.

3.3 Physical Requirements: Standard pipe laying length is 20'. 10' long joints may also be supplied, if available. Nominal drop pipe diameter should be selected by the Design Engineer based on required flow rate, total dynamic head, pump weight, and setting depth/pumping level, utilizing manufacturer-supplied guidelines on allowable tensile loading, pressure, and torque limitations.

3.4 Performance: All pipe supplied to this specification shall meet the performance requirements of ASTM D1785 for SCH80 pipe.

3.5 Joints: Pipe shall be joined using a spline lock joint. High-strength, acid-resistant, flexible thermoplastic splines shall be inserted into mating precision-machined grooves to provide full 360° restraint with evenly distributed loading. No external pipe-to-pipe restraining devices which clamp onto or otherwise damage the pipe surface as a result of point-loading shall be permitted. The joining system shall incorporate elastomeric sealing gaskets which are designed to provide a watertight seal. Note that this specification does not cover pipe with threaded joints.

3.6 Adapters: Drop pipe shall be joined to pumps, check valves, pitless adapters, or other components using a PVC or Stainless Steel Drop Pipe Adapter provided

▼ Offshore oil platform



by the same manufacturer as provides the drop pipe, and which utilizes the same spline lock joint as used on the drop pipe.

3.7 Marking: Drop pipe shall be legibly and permanently marked in ink with the following information:

- Manufacturer and Trade Name
- Nominal Size & SCH Rating
- Manufacturing Date Code
- (NSF-61)

3.8 Workmanship: Pipe and couplings shall be homogeneous throughout and free from visible cracks, holes, foreign inclusions, blisters and dents, interior roughness, and other injurious defects that may affect wall integrity. The pipe and couplings shall be as uniform as commercially practicable in color, opacity, density, and other physical characteristics.

4.0 INSTALLATION

Installation of drop pipe shall be in strict accordance with manufacturer's procedures and recommendations. Prior to installation, drop pipe shall be visually inspected to ensure there is no dirt or foreign matter in the pipe, and any such material which is found shall be removed before installation.

5.0 SUGGESTED SOURCE OF SUPPLY

Certa-Lok PVC Drop Pipe as supplied by:
CertainTeed Corporation
P.O. Box 860
Valley Forge, PA 19482
866-CT4-PIPE



◀ Irrigation supply well

QUICK SELECTION GUIDE



This guide provides a quick reference for evaluating proposed installations based on a set of generally conservative operational conditions. For a given surface discharge pressure, setting depth must be limited to the maximum values indicated.

This table should be used only for a preliminary assessment. Use the Design Worksheet which can be found at www.certainteed.com to obtain final calculations, or to engineer any installations which do not fit the table data or which exceed the setting depths shown.

MAXIMUM DISCHARGE PRESSURE AT WELL HEAD, PSI											
0 25 50 75 100 125 150 175 200											
SIZE	MAXIMUM PUMP SETTING DEPTH (FEET)									MAXIMUM FLOWRATE (GPM)*	MAXIMUM HP CAPACITY**
2"	422	380	338	296	253	211	169	127	84	80	20
3"	556	510	464	418	372	326	280	234	188	200	30
4"	489	441	394	347	299	252	205	157	110	350	50
5"	468	420	373	326	279	231	184	137	89	550	75
6"	493	445	397	349	300	252	204	156	108	800	100
8"	477	428	379	330	281	232	183	130	73	1400	125

* Based on a maximum flow velocity of 10 fps to control transient surge pressures; lower velocities are preferred.

** "Soft-start" controls are recommended to minimize imposed torque, especially on the higher HP motors (50 HP and above).

SUPPORTING DATA

SIZE		2"	3"	4"	5"	6"	8"
@ 73.4° or less	Maximum Hanging weight allowed at the top joint, lbs	1,307	3,209	4,506	6,612	9,617	15,214
	Maximum Pressure with threaded PVC Adapter, psi	250	230	200	175	170	150
	Maximum Pressure with threaded Stainless Steel Adapter, psi	375	309	288	274	280	232

DROP PIPE PRESSURE TABLES												
Flow GPM	2"		3"		4"		5"		6"		8"	
	Velocity fps	Friction Loss PSI/100 Ft	Velocity fps	Friction Loss PSI/100 Ft	Velocity fps	Friction Loss PSI/100 Ft	Velocity fps	Friction Loss PSI/100 Ft	Velocity fps	Friction Loss PSI/100 Ft	Velocity fps	Friction Loss PSI/100 Ft
10												
20	2.17	0.44										
30	3.26	0.93	1.46	0.13								
40	4.35	1.58	1.94	0.22								
50	5.43	2.38	2.43	0.34	1.40	0.09						
60	6.52	3.34	2.91	0.47	1.67	0.12						
70	7.61	4.45	3.40	0.63	1.95	0.16						
80	8.69	5.69	3.89	0.80	2.23	0.21	1.41	0.07				
90			4.37	1.00	2.51	0.26	1.59	0.08	1.11	0.04		
100			4.86	1.21	2.79	0.32	1.76	0.10	1.23	0.04		
150			7.29	2.57	4.19	0.67	2.65	0.22	1.85	0.09	1.05	0.02
200			9.71	4.38	5.58	1.14	3.53	0.37	2.46	0.16	1.41	0.04
250					6.98	1.72	4.41	0.56	3.08	0.23	1.76	0.06
300					8.37	2.41	5.29	0.79	3.69	0.33	2.11	0.08
350					9.77	3.21	6.17	1.05	4.31	0.44	2.46	0.11
400							7.06	1.35	4.92	0.56	2.81	0.14
450							7.94	1.67	5.54	0.70	3.16	0.18
500							8.82	2.03	6.15	0.85	3.51	0.22
550							9.70	2.43	6.77	1.01	3.86	0.26
600									7.38	1.19	4.22	0.30
700									8.62	1.58	4.92	0.40
800									9.85	2.02	5.62	0.52
900											6.32	0.64
1000											7.03	0.78
1100											7.73	0.93
1200											8.43	1.10
1300											9.13	1.27
1400											9.84	1.46

The Certa-Lok system utilizes precision-machined, self-aligning grooves in the pipe and coupling that allow a high-strength flexible spline to be inserted, resulting in a fully circumferential restrained joint that locks the pipe and coupling together. Flexible elastomeric gaskets (O-rings) in the coupling are designed to provide a reliable watertight pressure seal. Stainless steel torque control screws are used to prevent joint rotation.

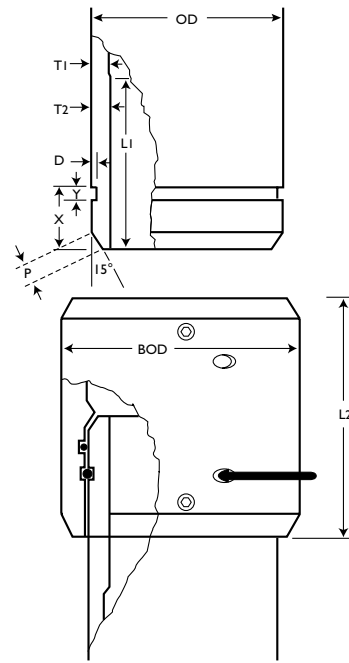

Size	Certa-Lok Drop Pipe			Certa-Lok Coupling			Certa-Lok Drop Pipe and Coupling							
	O.D.	WALL*		LI Min.	D		X	Y	P	BOD	L2	Laying Length	Approx. Weight Lbs./Ft. (with coupling)	Part No. Pipe & Coupling
2"	2.375	.218	.262	3.00	.100	.120	1.250	.313	1/4	3.200	4.50	20' 10'	1.002 1.049	661211 661112
3"	3.500	.300	.360	3.00	.100	.120	1.313	.375	1/4	4.380	4.50	20' 10'	1.991 2.079	662218 662119
4"	4.500	.337	.404	3.50	.125	.145	1.313	.375	1/4	5.470	5.00	20' 10'	2.909 3.039	663215 663116
5"	5.563	.375	.450	4.00	.125	.145	1.313	.375	1/4	6.625	5.50	20'	4.045	664212
6"	6.625	.432	.518	4.00	.125	.145	1.313	.375	1/4	7.840	6.00	20'	5.629	665219
8"	8.625	.500	.600	6.00	.135	.155	3.163	.500	21/32	10.190	10.00	20'	8.776	666216

* Minimum wall thickness

Notes

All dimensions are in inches and are subject to manufacturing tolerances.

Gaskets are Teflon® coated. Special lubricant may be used, but is generally not required.

CertainTeed also supplies 20' lengths of fully thickened Drop Pipe Nipple stock, which can be field cut (square cuts are essential) and grooved (a power tool is available) to place the pump at the required setting depth. 5' prefabricated joints are also available.

20' is standard length. Consult your distributor or CertainTeed for availability of 10' lengths prior to placing an order.

Packaging and Weights

Size	Laying Length	Feet per Fast-Pak	Fast-Paks per T/L	Feet per T/L	Lbs. per T/L
2"	20'	700	64	44800	44890
	10'	350	122	42700	44792
3"	20'	920	24	22080	43961
	10'	460	46	21160	43992
4"	20'	580	26	15080	43868
	10'	290	50	14500	44066
5"	20'	460	24	11040	44657
6"	20'	400	20	8000	45032
8"	20'	280	16	4480	39316

CERTA-LOK DROP PIPE COUPLING

INCLUDES: GASKETS, SPLINES AND SCREWS

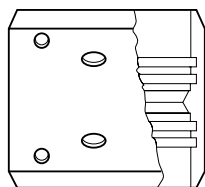

SIZE	PART NO.
2"	707209
3"	707216
4"	707223
5"	707230
6"	707247
8"	707254

CERTA-LOK DROP PIPE ADAPTER COUPLING

FEMALE BY SOLVENT WELD SOCKET
INCLUDES: GASKET, SPLINE AND SCREWS

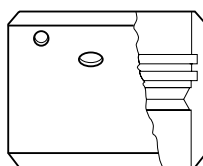

SIZE	PART NO.
2"	708114
3"	708121
4"	708138
5"	708145
6"	708152
8"	708169

CERTA-LOK PVC DROP PIPE ADAPTER

CERTA-LOK MALE BY MALE THREAD NPT

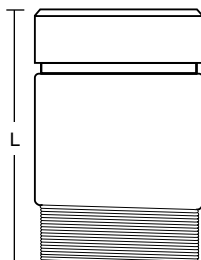

SIZE	PART NO.	L
2"	707513	6.00
3"	707520	6.25
4"	707537	7.00
5"	707544	7.25
6"	707551	7.50

CERTA-LOK 304 STAINLESS STEEL DROP PIPE ADAPTER

CERTA-LOK MALE BY MALE THREAD NPT

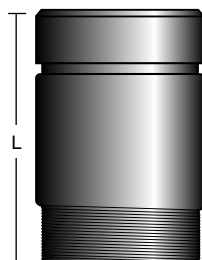

SIZE	PART NO.	L
2"	708015	6.00
3"	708022	6.00
4"	708039	6.00
5"	708046	6.00
6"	708053	6.00
8"	708060	9.00

CERTA-LOK PVC DROP PIPE NIPPLE

CERTA-LOK MALE BY PLAIN END

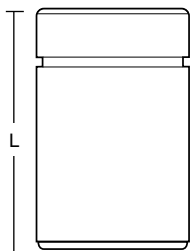

SIZE	PART NO.	L
2"	707414	6.00
3"	707421	6.25
4"	707438	7.00
5"	707445	7.25
6"	707452	7.50
8"	707469	8.00

CERTA-LOK DROP PIPE TORQUE CONTROL SCREWS

STAINLESS STEEL

SIZES	COUPLING SIZES	PART NO.
3/8" x 3/8" L	2" - 3"	549519
3/8" x 1/2" L	4" - 8"	549526



SPLINE				O-RING (GASKET)	
SIZE	PART NUMBER	SIZE (IN.)	LENGTH (IN.)	SIZE	PART NUMBER
2"	865701	3/16 RND.	10.5	2"	861215
3"	865718	1/4 RND.	16	3"	861222
4"	865725	1/4 RND.	18	4"	861239
5"	865732	1/4 RND.	22	5"	861246
6"	865749	1/4 RND.	24	6"	861253
8"	865756	5/16 SQ.	32	8"	862717

Certa-Lok Drop Pipe Application And Installation Guidelines

Certa-Lok Drop Pipe for submersible pumps is engineered and manufactured to provide long and reliable service in most well applications. For best results, the following guidelines must be observed when installing Certa-Lok Drop Pipe.

The CertainTeed Design Worksheet (www.certainteed.com) must be consulted to determine the appropriate size pipe for the proposed application. Select size carefully to accommodate the maximum anticipated flow rate, and always account for worst-case transient conditions (e.g., surge pressures, increased pressure at start-up, etc.). The discharge pressure used must account for the effect of any upstream piping, including changes of elevation. Maximum flow velocity of 10 fps is recommended to control transient surge pressures; lower velocities are preferred.

Handle pipe and couplings with normal care at all times, being particularly careful not to strike the pipe with any objects, especially in colder weather. When unloading the truck, lower pipe slowly to the ground.

Important: Do not use PVC Drop Pipe if there is the potential for pump-generated heat, which can occur if the system is allowed to operate continuously under zero flow/pump shut-off head conditions. Heat can greatly reduce the strength of thermoplastic materials. A safety cable or rope must be used on all installations due to this potential problem.

All Certa-Lok Drop Pipe application guidelines are given with the assumption that a check-valve is used at or within 20 feet of the pump and at higher elevations, as required, to control water hammer.

If surge pressures are not totally predictable due to potential variations in system operation, a properly sized pressure relief valve must be installed at the well-head. Use the Design Worksheet to verify that maximum system pressures, which develop when the relief valve actuates, do not exceed published pressure ratings.

Note: As CertainTeed cannot predict the degree of pump motion that may be experienced in a particular application due to factors such as mechanical unbalance, a centralizer or torque arrestor located directly above the pump should be considered, especially on deeper wells, to prevent the Drop Pipe from whipping and vibrating. Use and spacing of additional centralizers above the pump should be determined based on the particular installation conditions.

The Certa-Lok system incorporates coupling set-screws, which are tightened to provide resistance against torque imposed on the system by the pump motor during start-up. Set-screws should be tightened after the joint has been assembled and slack removed; manually filling the Drop Pipe with water before starting the pump will increase hanging weight, helping to remove slack from the joint and air from the system. Tighten with an allen wrench until set-screws are just touching the pipe; then torque each screw one-half to one full turn or until snug.



Caution: Excessive tightening of the set-screws will cause high local stresses, and may result in a joint that leaks under pressure. If a stainless steel adapter is used, a small indentation, or countersink, is recommended to provide a recess for the set-screws. This can be accomplished with a conventional power drill, after using the Certa-Lok coupling to mark the set-screw hole locations.

“Soft-start” controls are recommended to minimize imposed torque, especially on the higher HP motors (50 HP and above).

buildingresponsibly™

Building Responsibly with PVC Pipe

- PVC resin starts with two simple building blocks: chlorine (57%) from common salt, a plentiful inexhaustible raw material, and ethylene (43%) from natural gas. Most of the natural gas utilized to manufacture ethylene is domestically produced, which reduces consumption of imported oil products.
- PVC Pipe manufacturing is an extremely efficient process. The ability to immediately return scrap and off-specification materials (regrind) directly into the manufacturing process results in virtually no manufacturing waste.
- PVC Pipes are completely recyclable and consume less energy to produce than alternative pipes.
- Smooth and corrosion resistant PVC lowers flow losses and reduces energy costs for pumping water.
- Durability and long-life: The number of recorded failures in PVC pipes is low compared to other materials (AWWA Research Foundation, 2005)—valuable water resources are conserved.
- Considering equipment utilization and reduced traffic disruption, trenchless construction methods using restrained-joint PVC pipes result in significantly lower carbon outputs compared to conventional open-cut methods.
- PVC is often used to pump reclaimed, treated wastewater for applications such as irrigation of parks—conserves highly treated, expensive drinking water.

ASK ABOUT OUR OTHER CERTAINTEED PRODUCTS AND SYSTEMS:

EXTERIOR: ROOFING • SIDING • WINDOWS • FENCE • RAILING • TRIM • DECKING • FOUNDATIONS • PIPE
INTERIOR: INSULATION • GYPSUM • CEILINGS

CertainTeed Corporation
P.O. Box 860
Valley Forge, PA 19482
Phone: 866-CT4-PIPE (866-284-7473)
Fax: 610-254-5428
www.certainteed.com

CertainTeed